

## IMPROVEMENT OF PADDLES IN ORDER TO INCREASE THE LEVEL OF COTTON DRYING IN THE 2SB-10 DRUM DRYER

**X. Oltmishboyev**

44-20 YSTJ guruh talabasi, Farg‘ona politexnika institute, Farg‘ona,  
O‘zbekiston

**M. Valijonov**

44-20 YSTJ guruh talabasi, Farg‘ona politexnika institute, Farg‘ona,  
O‘zbekiston

**A. Sharifjonov**

44-20 YSTJ guruh talabasi, Farg‘ona politexnika institute, Farg‘ona,  
O‘zbekiston

### **Abstract**

The 2SB-10 type of drying drum used in cotton ginning enterprises reduces its air consumption by installing paddles at an angle of 80 degrees in the middle.

**Keywords:** 2SB-10 drying drum, blades, air consumption, 80 degrees,

### **Introduction**

According to the coordinated technological process during the processing of cotton raw materials, the drying operation is carried out in the drying-cleaning departments of cotton processing facilities, and in the cleaning departments of cotton ginning enterprises. These departments are equipped with a complex of technological machines, including drying drums.

### **The main part**

In recent years, 2SB-10, SBO straight-flow drum dryers (in which the cotton raw material and the drying agent move in the same direction) have been widely used in the cotton ginning industry for drying cotton raw materials.

The 2SB-10 drum dryer is a drying drum made of metal sheet with a diameter of 3200 mm and a length of 10000 mm. Its base is made of 2 mm steel sheet and is attached to a special frame. Inside the drum, 12 shovels are placed along its length, which serve to lift and distribute cotton raw materials according to the size of the

drum. In order to create the best hydrodynamic conditions for convective heat exchange and to give rigidity to the structure, 250 mm high cross blades are installed per meter. The drum has 3 rows of tubular bars that suspend the raw cotton material along the drying chamber 6000 mm long. Its function is to increase the time of cotton raw material in the drop zone, where the drying agent actively affects the material. Cotton raw material is transferred to the drum by means of a screw conveyor with a diameter of 300 mm and an inclination of 300 from the horizon. This supply device is transmitted to the drum through a shaft with a diameter of 1190 mm and fixed to the front part of the drum. The rotation frequency of the drum is 10 min<sup>-1</sup>, filling with raw cotton is 30% of the volume of the drum, i.e. 1200 - 1500 kg of raw cotton.

The drying agent (2) is also transferred to the drum from the place where the wet cotton raw material is transferred to the drum through the supply auger (1). The cotton raw material is lifted up with the help of paddles (5) and the drying agent passes between them during its descent. In this case, the drying agent gives heat to the wet material, absorbs the moisture and is discharged to the atmosphere through the exhaust pipe. And after several times of rising and falling, the cotton raw material is dried to a certain extent and leaves the drum (4). In this case, cotton raw material is removed using shovels installed at the end of the drum.

As the drying agent partially sucks the surrounding air while passing through the needle (3), it prevents the cotton being fed into the drum with the auger (1) from spilling, and the cotton is pushed forward in the air stream. The drum shaft is driven by an electric motor and a reducer (9). The temperature of the drying agent supplied to the dryer can be increased up to 280°C. When wet cotton is dried in the dryer, the temperature of the drying agent in the first four meters of the drum decreases from 280°C to 125°C, and in this part, the cotton raw material is mainly heated, and the heating surface is large (250 m<sup>2</sup>/kg) and the moisture in the fiber can be evaporated. In the next part of the drum, the temperature of the drying agent decreases to 70.80 °C, and the evaporation surface of the seed is much less (1.0 m<sup>2</sup>/kg), which slows down the release of moisture from the cotton raw material.

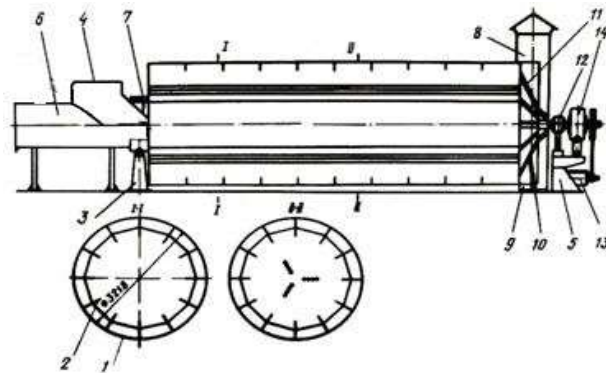

Fig. 1. Technological scheme of the 2SB-10 drying drum

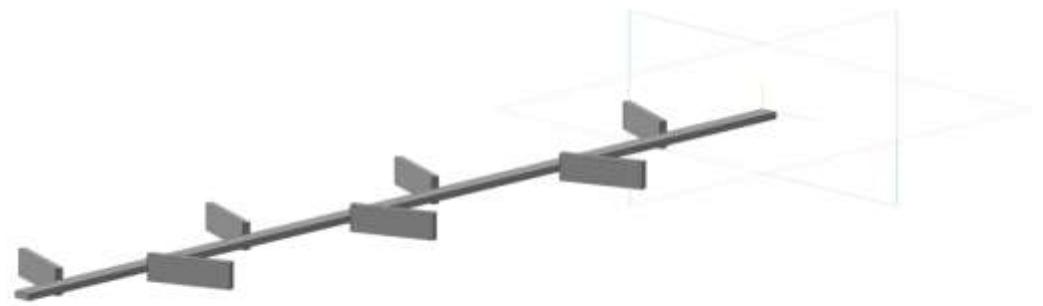

Fig. 2. Improved part

### Conclusion

Through our proposal, which is introduced into the drying drum used in cotton ginning enterprises, we can achieve better drying of seeded cotton, reduce air consumption and reduce the moisture content of seeded cotton. This can also make the rest of the equipment work better and improve cleaning efficiency.

### References

1. E. Zikriyoyev "Preliminary processing of cotton", Tashkent-2002.
2. M. Omonov "Cotton preliminary processing spravochnik" Tashkent-2008.
3. Decree of the President of the Republic of Uzbekistan dated 10.01.2023 No. PF-2
4. Babadjanov M.A. "Technological process design" textbook, Tashkent, Cholpon-2009.
5. G. J. Jabborov "Technology of seed cotton processing". "Teacher" Tashkent-1987.

