

## Analysis of the design of stone holders in cotton cleaning processes

Assistant:

Imomnazarov Khurshidbek Khushnazar's boy

Student of group 88-21

Tojimatova Feruza Mamaro'zi's girl

**Abstract:** This article analyzes the design of stone holders used in cotton ginning technological processes and proposes an improved design of stone holders.

**Keywords:** cottonseed, stone crusher, heavy mixture, pockets, pneumatic transport, speed, air pressure

**Introduction.** Comprehensive measures are being implemented to develop the cotton sector, modernize and technically re-equip cotton ginning enterprises, increase the profitability of production and processing of cotton raw materials, as well as the competitiveness of manufactured products.

Because the ever-increasing demand for cotton and its products indicates the need to use modern equipment and technologies in the cotton ginning industry. One of the current goals is to radically improve the management system of the cotton sector, expand the production of competitive and high-quality finished products with high added value, and further export them to major foreign markets. And a number of new projects are being developed in this direction.

The efficiency of the equipment installed in the technological process of cotton ginning enterprises, their uninterrupted operation, has a significant impact on the composition of cotton. Heavy impurities in the cotton content cause damage to the working parts of the ginning machines and the teeth of the saws of gins and linters during its processing. Such a change leads to damage to the seeds and fibers during the separation of fiber from the seed in the gin. This in turn leads to a decrease in the cleaning efficiency of cotton ginning machines and the inclusion of more cotton pieces in the waste. In addition, heavy impurities can cause fires as a result of hitting the metal and working bodies of the processing machines. Therefore, the ingress of heavy impurities into the working chambers of cotton processing machines has always been the focus of attention of scientists and industry experts in this field, and they have been looking for ways to completely retain heavy impurities in the air-carrying device.



D.L. Kelbert [1] conducted a study on the causes of fires in the process of separating fiber from the grain in the saw teeth of cotton ginners, gins and linters. It was determined that this was mainly caused by metal fragments (nails, nuts, washers) in the composition of heavy alloys. The composition of heavy alloys trapped by stone traps installed in the technological process of cotton ginners is shown.

The principle of operation of the air-assisted conveyor is that atmospheric air, under the flow formed due to the pressure difference, carries the transported material along with it and pushes it into the pipe. The cotton moves in a suspended state inside the pipe and reaches the separator. The separator separates the material from the carrier air and transfers it to the next technological unit.

The advantage of the suction air conveyor is that the working pipeline system can be easily and conveniently changed depending on the location of the cotton ginning plants, and the length of the pneumatic line can be extended by connecting additional pipes to the initial pipes. The production capacity of the air conveyor depends on the production capacity of the cotton ginning plant. For an advanced cotton ginning plant with one battery, it is 10 tons per hour.

With the growth of the cotton production rate, the cotton processing industry sets itself the task of increasing production capacity, increasing the productivity of equipment, and improving product quality. The implementation of these tasks is largely dependent on the operation of the air conveyor installed in the area. Because it is directly integrated into the continuous technological process of the cotton ginning plant and is an important part of its initial and working rate.

Stone holders are divided into two types depending on the installation location. The first is linear stone holders. They are located in the line of the air conveyor and are installed before the separator. The second is non-linear stone holders, which are installed after the separator.

In order to achieve the highest possible retention of heavy impurities and metal fragments in the cotton, it is necessary to study the movement of cotton in the separation chamber of the devices created. The intended purpose is to determine the trajectories of cotton and heavy impurities in the working chambers of newly created multi-pocket radial and cylindrical stone holders. Using this trajectory, it will be possible to determine the location of the pockets and elastic plates in the working

chamber. Currently, the following stone holders and their improved designs are in operation at cotton ginning enterprises.

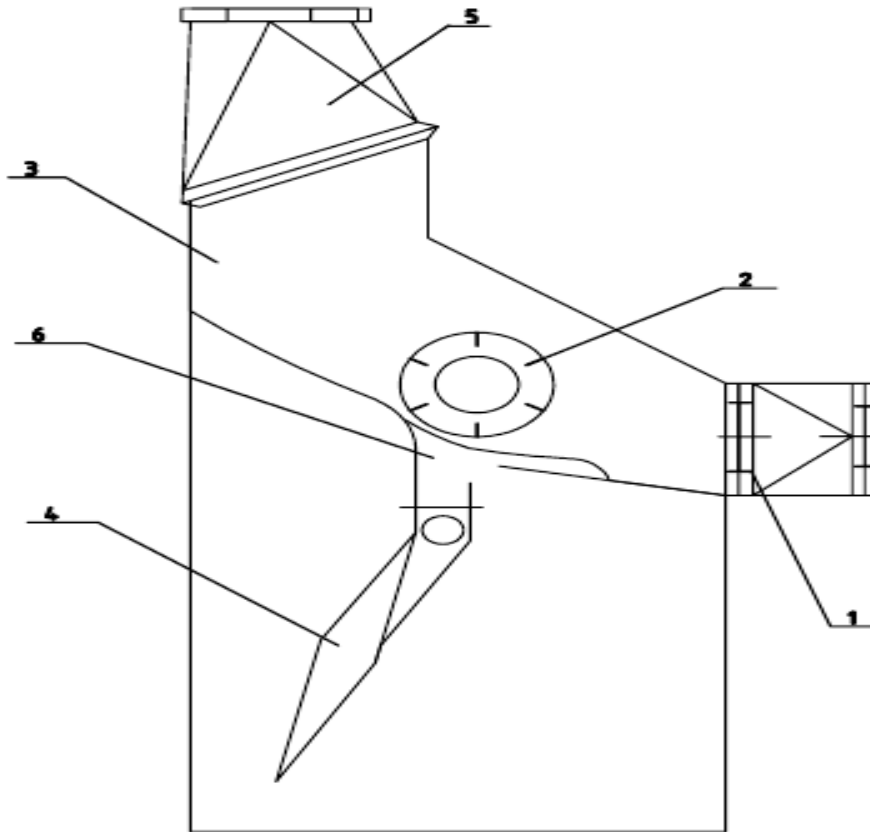

### **2CHTL heavy duty mixing device.**

**1-pipe for transferring cotton seeds into the device, 2- aspiration chamber, 3- return wall, 4- heavy impurities separator, 5- pipe for transferring cotton seeds from the device, 6- observation hatch.**

In order to increase the efficiency of the stone catcher, that is, to capture and separate heavy impurities in the cotton seed coming from the pneumatic transport system, new designs of multi-pocket stone catcher have been proposed. When analyzing the designs of the proposed stone catcher, the following factors were identified and analyzed.

In this case, in order to achieve the highest level of capture of heavy impurities in the cotton by the multi-pocket stone catcher, it is necessary to determine the most convenient location of the pockets. That is, cotton and heavy objects, having different specific masses and speeds, move along different trajectories in the transition areas during air transportation. Since heavy objects have a larger mass



than cotton and move along different trajectories, it is necessary to know where to install the pocket stone catcher separation chamber to capture them.

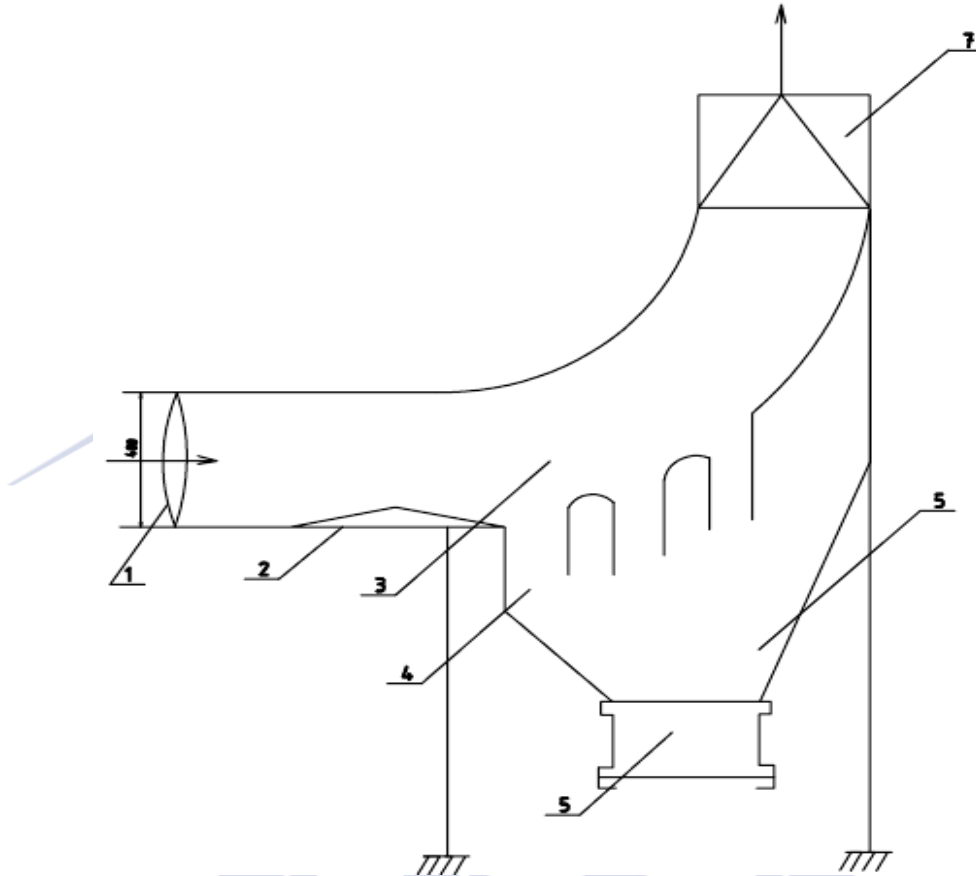

#### Proposed heavy impurities capture device

**1- inlet pipe; 2 – diverter; 3 – separation chamber;  
4 – pockets; 5 – receiving device; 6 – separator; 7 – outlet pipe.**

When determining the location of the pockets in the working chamber, possible situations of movement of cotton and heavy mixtures along the height of the pipe were taken. In this case, cotton and heavy mixtures were mainly studied in two cases in the pipes. In the first case, we consider that cotton and heavy mixtures move along the central axis of the pipe and in the middle of its lower plane. In the second case, we assume that cotton and heavy mixtures move in the area between the central axis of the pipe and its upper plane. Having studied the movements of cotton and heavy mixtures inside the pipe in these cases, we determined the coordinates of the intersection points of their movement trajectories with the pipe



walls. Based on the obtained points, the first pocket is installed in the lower part of the working chamber. Heavy mixtures with large sizes mainly fall into it.

The second pocket is installed in a stepped manner at a certain distance after the first pocket, and mainly medium-sized heavy impurities fall into it. The third pocket has the ability to retain small impurities from the cotton content. As a result of the theoretically based installation of these pockets, the loss of cotton with heavy impurities is also reduced. In addition, the stepped installation of the pockets causes the cotton moving in the form of pieces to vibrate as a result of impact. This vibration also makes it possible to separate heavy impurities that are well bonded to the cotton.

**Conclusion.** As a result of the analysis of the designs of stone traps, according to the operating processes of the currently operating stone traps, the use of multi-pocket designs compared to the 1st pocket leads to an improvement in the efficiency of the processes of retaining heavy impurities in the cotton content.

#### REFERENCES

1. “O‘z paxtasanoat” uyushmasi “Paxtani dastlabki ishlash muvofiqlashtirilgan texnologiyasi”, PDI 01-2007, Toshkent, 2007.
2. Jabborov G‘.J.va boshqalar «CHigitli paxtani ishlash texnologiyasi», Darslik. «O‘qituvchi». Toshkent. 1987.
3. Miroshnichenko G.I. Основы проектирования машин первичной обработки хлопка. “Mashinostroenie”. Moskva 1972.
4. Babadjanov M.A “Texnologik jarayonlarni loyixalash”. Darslik. Chulpon nomidagi nashriyot matbaa-ijodiy uyi, Toshkent. 2009.
5. “Uz paxtasanoat” Aksiyadorlik uyushmasi, “Paxta tozalash IChB” OAJ. Paxtani dastlabki ishlash bo‘yicha spravochnik. F.B.Omonovning umumiy tahriri ostida. Toshkent. 2008.
6. Spravochnik po pervichnoy obrabotke xlopka (I i 11 kniga). Pod redaksiyey Maksudova I.T.i Nuralieva A.N. «Mexnat» Tashkent, 1994, 1995.

