

IMPROVING COLOSSAL GRID OF 5LP LINTING TECHNOLOGY PROSESSES AND INITIAL IMPROVEMENT

Z. Kholiqova

Lecturer, Fergana state of technical university, Fergana, Uzbekistan

Annotation

Adjustment of the supply of seed to the linter is performed depending on the density of the seed mass in the working chamber. The performance of the linter on the seed is carried out by changing the length of the chain connecting the variator with the seed density lever in the working chamber and by changing the position of the load on the lever of the density lever.

Keywords: Seeds, grate, stirrer, saw shaft, seed comb, air blower.

Introduction

Columns of 5LP linter equipment are made of U8 steel. Lower operating costs are achieved by installing the improved U13A steel plate shown in the above picture on the working part of the grate, that is, the working part where the saw disc feeds the fluff. Also, the installation of the proposed metal plate will save time and resources (new colostrum) required for replacing spread colostrums, preventing broken pieces of seed from passing through the fluff due to spreading.

The main task of the linter equipment installed in the linting department of cotton gins is to separate the fluff from the surface of the seed mechanically, that is, with saw teeth. Linters are subject to the following requirements: seed and lint should not be damaged during linting, impurities and impurities should not be added to the lint, the mechanism (tool-equipment) that controls the quality of lint, the level of fluffiness of the seed, and the performance of the linter should work.

The main indicators of linter work are the level of fluff separation and the productivity of the seed.

There are two ways to configure the linter workflow:

- by changing the position of the seed comb;
- by changing the seed supply procedure.



By changing the position of the seed comb, the degree of fluff separation from the seed is changed. By changing the seeding mode, the linter's seeding performance is changed.

Adjustment of the supply of seed to the linter is performed depending on the density of the seed mass in the working chamber. The performance of the linter on the seed is carried out by changing the length of the chain connecting the variator with the seed density lever in the working chamber and by changing the position of the load on the lever of the density lever. The adjustment of the separation of dust and dirt is done by changing the position of the dust separation rail of the air chamber.

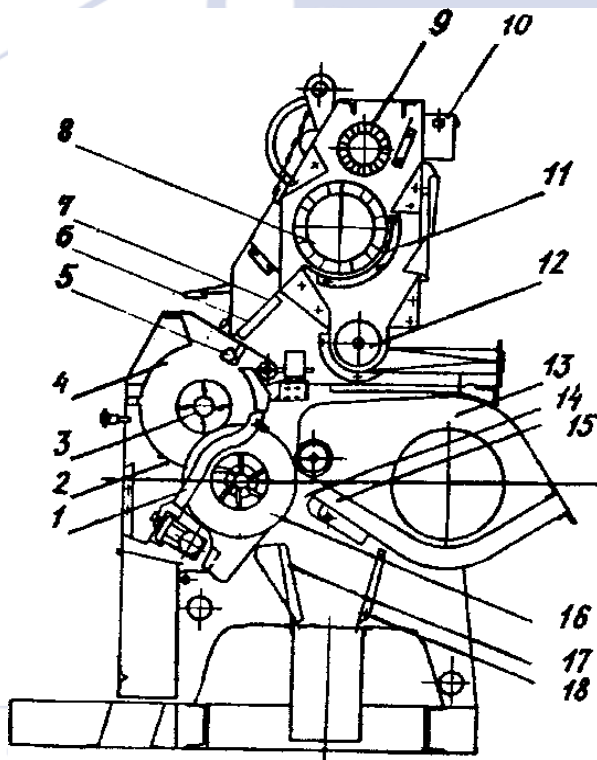

Fig. 1. Linter machine type 5-LP

1st rib fence; 2- seed comb; 3- trimmer; 4- working chamber; 5th density stack; 6-magnetic plate; Item 7 is a nova; 8-leveling drum; 9-supporting drum; 10- linter provider; 11-net; 12th waste auger; 13-air chamber; 14-dead pile; 15th pipe; 16-saw cylinder; 17th small rod; 18-big nov.



The linter is equipped with a working chamber lifting mechanism. The mechanism is controlled by a button on the linter control panel. The kinematic scheme of the rotary working bodies of the 5LP-linter is shown.

Linter production indicators are characterized by three different indicators:

- Lint separation productivity (kg/hour);
- Productivity of hairy seed transfer (kg/h);
- Lint acquisition percentage (%).

These indicators are interconnected as follows:

$$R = Q \cdot C / 100 \text{ kg/h}$$

Where: R is linter performance, lint by lint

Q - productivity of seed transfer

S is the degree of lint removal from the seed, in %.

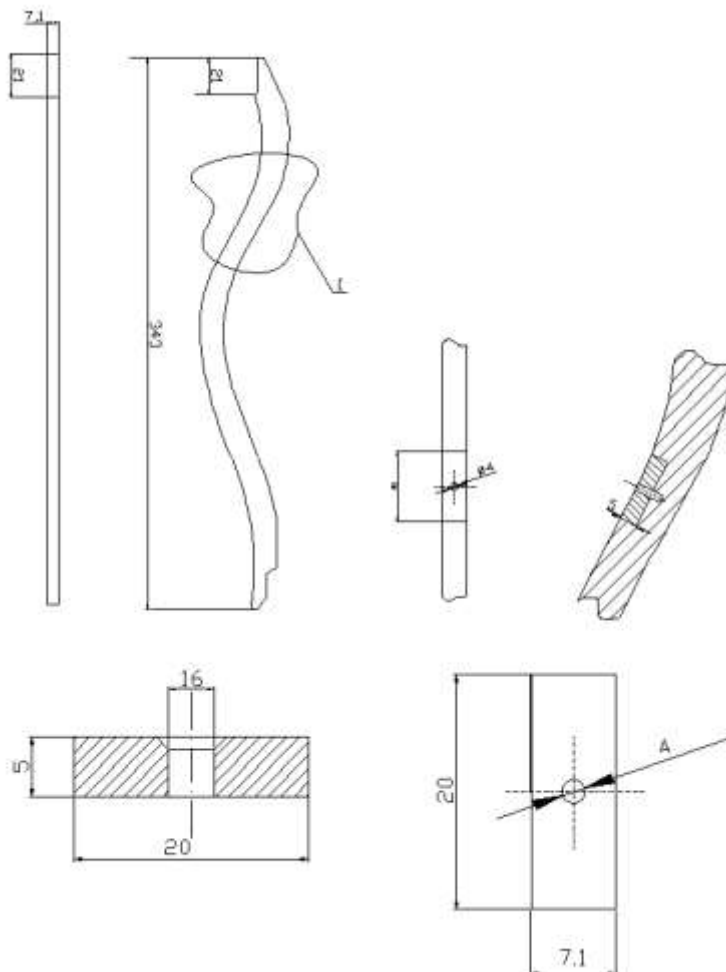

e and
use



A-colossal grid, b-cut view, v-metal plate.

Fig. 2. The proposed U13A steel metal plate

Columns of 5LP linter equipment are made of U8 steel. Lower operating costs are achieved by installing the improved U13A steel plate shown in the above picture on the working part of the colosnik, that is, the working part where the saw disc feeds the fluff. Also, the installation of the proposed metal plate will save time and resources (new colostrum) required for replacing spread colostrums, preventing broken pieces of seed from passing through the fluff due to spreading.

The 5 LP linter under development has a linter capacity of 100 kg/h and a seed capacity of 2000 kg/h. A seed receiver-cleaner (KPP) is installed on the linter.

Seed falling into the working chamber is distributed in the required amount with the help of the density handle and variator brand IVA-40.

References:

1. Salimov, A., & Akhmatov, M. (2005). *Preliminary Processing of Cotton*. Training Manual. Tashkent: Knowledge Publishing.
2. Babadzhanov, M.A. (2009). *Technological Process Design*. Textbook. Tashkent: Cholpon.
3. Jabborov, G.J. (1987). *Technology of Seed Cotton Processing*. Tashkent: Teacher Publishing.
4. Salimov, O.A., Khusanova, S.A., Salimov, M., & Rahimjonov, A.R. (2022). Study of Factors Affecting the Quality of Raw Cotton During Storage and Processing. *Central Asian Journal of Theoretical & Applied Sciences*, 3(3), 40–46.
5. — Salimov, A., Salimov, O., Khusanova, Sh., & Khakimov, I. (2020). The Problems of Natural Fiber and Textile Materials on Fire Resistance. *SAARJ Journal Akademia: An International Multidisciplinary Research Journal*, April 2020 Issue.
6. Sarimsakov, O.Sh., & Khusanova, Sh.A. (2020). Improvement of the Process in Disassembling of Cotton Stack and Transferring the Cotton into Pneumotransport. *International Journal of Advanced Science and Technology*, 29(7), 10849–10857.

7. Ergashev, Y., Khusanova, S., & Axmadjonov, D. (2022). Analysis of the Fiber Quality of Cotton Varieties Grown by Region. *Gospodarka i Innowacje*, 21, 242–244.
8. Ahmedov, M.Kh., Tuychiev, T.O., Ismoilov, A.A., & Khusanova, S.A. (2021). Algorithm of the Estimation of the Moving the Raw Cotton on Surfaces of the Pallet of the Mechanism of the Presenting Ginning Machines. *Scientific-Technical Journal*, 4(3), 69–74.
9. Ergashev, Y., Khusanova, A.S., & Babayeva, M. (2020). Analysis of Dynamic Characteristics of Selective Technology of Sawing. *Fergana Scientific-Technical Journal*, Issue 1.
10. Sattorov, N., & Khusanova, S.A. (2020). Selective Technologies in Sawing. *Intellectual Property Agency of the Republic of Uzbekistan*, DGU08698.
11. Khusanova, A.S., & Toshmirzayev, Q. (2021). Selective Technologies in Sawing. *Collection of Conference Materials*, pp. 23–24.

Research Science and Innovation House