

THE PERFORMANCE IMPROVING THE PERFORMANCE OF DUST COLLECTORS VZP-1200 AND ADDING NEW INNOVATION TECHNOLOGIES

Ergashev Yuldashali, Ogiloy A. Bakhtiyorova

Fergana state Technical University, Fergana, Uzbekistan

Abstract

The efficiency of the dust collectors has been increased by increasing the efficiency of the dust collectors and trapping the fibrous waste in the air flow and passing the remaining air flow to the dust collector. The calculation of the chain drive installed in the improved equipment and the determination of the number of stars were carried out.

Keywords: Cylinder, dust holder, air flow, hopper, vacuum valve, reducer.

Introduction

One of the features of the pneumatic transport of seeded cotton and its products in the conditions of cotton cleaning enterprises is the formation of large and dusty cotton dust on the inner surfaces of the pipes, conveyors and equipment.

In contrast to dust collectors of the UIV, SS-6, SP-3 type, VZP counter-circulation air dust collectors have a sufficient impact on the work process. At the same time, counter-circulating air flow dust collectors have a slightly higher efficiency coefficient, which increases the reliability of their operation.

Counter-circulation equipment is a dry-type dust collector. The VZP dryer produced at the Moscow Textile Academy is successfully used in the chemical and other branches of industry. One of their main features compared to other dust collectors is their high efficiency. VZP-800 and VZP-1200 dust collectors consist of a cylindrical body, in the lower part of which there is a tangential pile 2, an inlet pipe 3, which works to transfer the primary flow of settled and dusty air. A cylindrical sucker is placed at the border of the rotor, which belongs to the axis.

It is connected with the upper part of the cone. On the outer surface of the rotor (returner) 5 is placed, its shape is truncated conical. The hopper part 6, the perforated dust holder is attached with a vacuum-valve flange. At the top of the dust holder, there is a pipe 7 for discharging the cleaned air. At the same time, this pipe



performs the function of rotating the dusty air coming from the second flow of dusty air. A secondary dusty air distribution valve 9 is placed in the primary dusty air inlet pipe.

VZP pulverizers work as follows: Two unidirectional streams of dusty air enter a mixer or separation zone located at the top of the suction pipe and the primary filter. Particles caught under centrifugal force are separated (separated) on the wall and fall down from the hopper with a downward flow. It is removed from the ground through a non-stop vacuum valve. As the downstream secondary flow spirals down the wall of the equipment, the return washer pulls it back up and joins the primary flow. Along with it, it leaves the suction pipe.

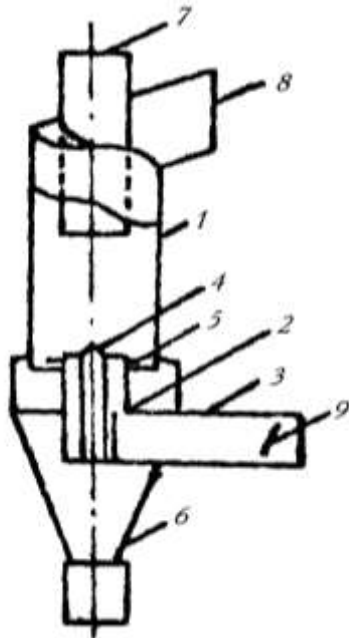

1st corps; 2nd tangential groove; 3-lower inlet pipe; 4-suction tube switch; 5th return puck; 6th lower bunker; 7-purified air outlet pipe; 8-upper inlet pipe; 9 valve.

Figure 1. Scheme of VZP switches.

VZP is a unique aerodynamic device. In it, the large dust particles coming from the CC-15A separator get tangled due to the rotational movement of the air flow and reduce the useful efficiency of the VZP device. It contains small particles and mineral impurities, and captures small fractions [21].

Recently, the air productivity in cotton ginning industry is 3 and 6 m³ Vortex dust collectors VZP-800 and VZP-1200 with /s are widely used. These converging



vortex dust collectors belong to the group of dry centrifugal air cleaning dust collectors and are designed to clean recycled air from dust.

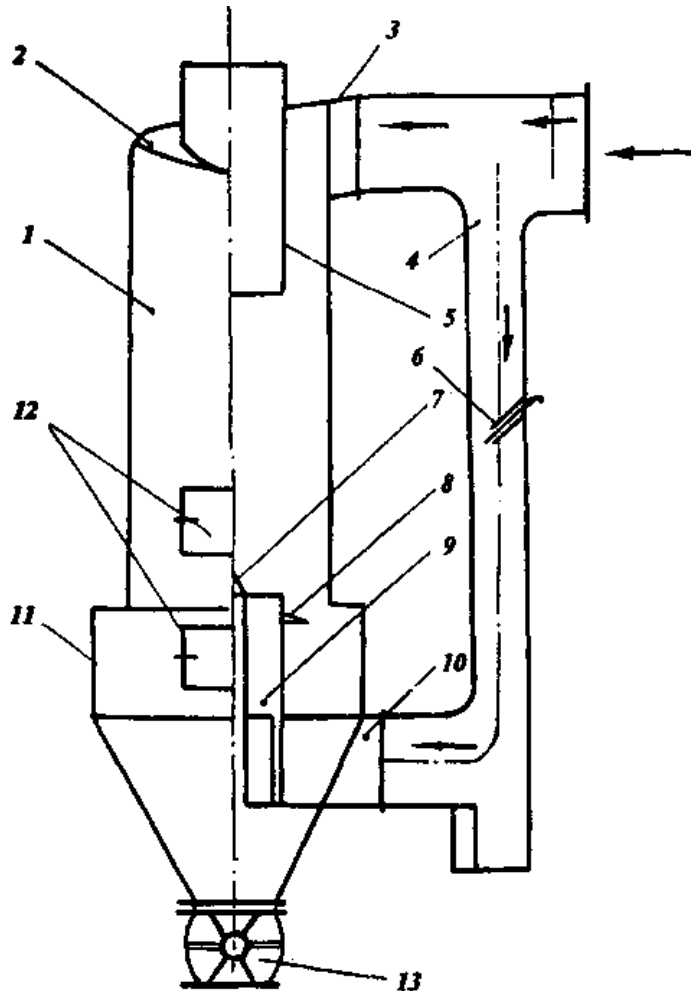

1 - separation chamber; 2 - upstream vortex; 3 - pipe; 4 - supply air duct; 5 - air exhaust pipe; 6 - skylight; 7 - squeezer; 8 - return puck; 9 - downstream swirler; 10 - pipe; 11 - bunker; 12 - observation cover; 13 - vacuum valve.

Figure 2. Opposite VZP dust holder .

Research Science and
Innovation House



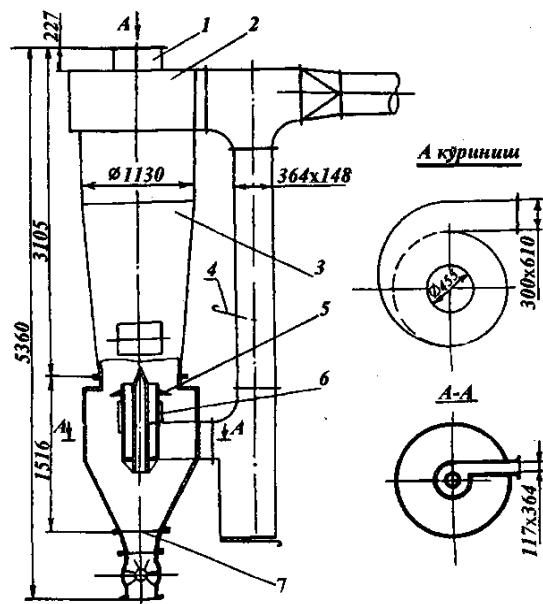

1 - dust extraction pipe; 2 - upstream vortex; 3 - separation chamber; 4 - window;
5 - return puck; 6 - downstream swirler; 7 - dust extraction hole.

Figure 3. Countercurrent VZP-MZ dust holder.

It is designed to clean the used air of the air-assisted transportation system for cotton. It is recommended to remove the dirt by air instead of the screw conveyor in order to avoid the large amount of dust coming out of the dust extraction holes. Each dedusting device is characterized by its dust capture efficiency, which is determined by the following equation:

$$\eta = \frac{G_2}{G_1} \cdot 100 \quad (1)$$

here: G_1 - total weight of dust in processed air, mg;

G_2 - dust weight captured by the dedusting device, mg.

Dust capture efficiency can also be determined by the difference in air pollution entering and leaving the dust collector.

$$\eta = \frac{d_1 - d_2}{d_1} \cdot 100\% \quad (2)$$

here: d_1 - dustiness of the air entering the dust holder, mg/m^3 ;

d_2 - dustiness of the air coming out of the dust holder, mg/m^3 .

$$\eta = [1 - (1 - \eta_1) \cdot (1 - \eta_2) \cdot k \cdot (1 - \eta_n)] \cdot 100\% \quad (3)$$

here: η_1, η_2, η_n - the dust collection efficiency, expressed as a percentage of the unit of each successive step.

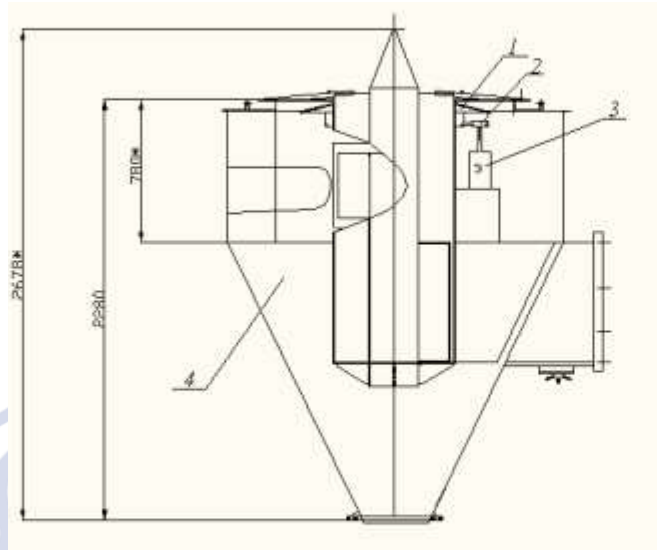

Figure 4. Calculation of rotation of the return washer of the dust holder

Power $P = 0,75 \text{ kW}$,

Electric motor brand #71A2,

Rotational speed 2840 RPM,

$$\eta_T = 0,95 \div 0,97$$

The diameter of the rotor of the rotating return washer $d_2 = 630 \text{ mm}$

1. Power consumption

$$P_T = P \cdot \eta_T = 0,75 \cdot 10^3 \cdot 0,96 = 0,72 \text{ kW} \quad (4)$$

2. Electric motor angular speed;

$$\omega_{\text{э.д.}} = \frac{\pi \cdot n}{30} = \frac{3,14 \cdot 2840}{30} = 297 \text{ ref / s} \quad (5)$$

3. The work done by the puck returner.

$$T_1 = \frac{P}{\omega} = \frac{0,72 \cdot 10^3}{297} = 2,43 \cdot 10^3 \text{ Hmmm}$$

4. The diameter of the electric motor mounted pulley

$$d_1 = \frac{d_2}{u_T(1-\varepsilon)} = \frac{630}{2 \cdot (1-0,015)} = \frac{630}{1,97} = 320 \text{ hmmm} \quad (6)$$

5. Angular speed of the return puck

$$\omega_B = \frac{\omega_{\text{э.д.}}}{u_T} = \frac{297}{2} = 148,5 \text{ rad / s} \quad (7)$$

Useful efficiency of the belt drive



$$\Phi_{HK} = \frac{\omega_{\text{э.д.}} - \omega_B}{\omega_{\text{э.д.}}} \cdot 100 = \frac{297 - 148,5}{297} \cdot 100 = 0,5\% \quad (8)$$

6. Choose the maximum and minimum distances between axes

$$a_{\min} = 0,55(d_1 + d_2) + h = 0,55 \cdot (320 + 630) + 10,5 = 533\text{mm},$$

$$a_{\max} = d_1 + d_2 = 320 + 630 = 950\text{mm}.$$

here: h -remin thickness, $h = 10,5 \text{ mm}$.

From this we can choose the distance between the axes

$$a_p = 1000\text{mm},$$

7. The length of the rubber of the required belt drive

$$L = 2 \cdot a_p + 0,5 \cdot \pi \cdot (d_1 + d_2) + \frac{(d_2 - d_1)^2}{4 \cdot a_p} = 2 \cdot 1000 + 0,5 \cdot 3,14 \cdot (320 + 630) + \frac{(630 - 320)^2}{4 \cdot 1000} = 2000 + 1491,5 + 24 = 3515,525$$

Belt length from belt drives $L = 3550 \text{ mm}$, we accept that

8. Selecting the distance between the axles for the resulting frame

$$w = 0,5 \cdot \pi \cdot (d_1 + d_2) = 0,5 \cdot 3,14 \cdot (320 + 630) = 1491,5\text{mm},$$

$$y = (d_2 - d_1)^2 = (630 - 320)^2 = 9,61 \cdot 10^4 \text{mm}^2$$

$$a_p = 0,25 \cdot \left[(L - w) + \sqrt{(L - w)^2 - 2 \cdot y} \right] = 0,25 \cdot \left[2058,5 + \sqrt{4045222,25} \right] = 1017,5\text{mm},$$

To make it easier to put remini on the tape $0,01 \cdot L = 0,01 \cdot 3550 = 35,5 \text{ mm}$,

For belt tension $0,025 \cdot L = 0,025 \cdot 3550 = 88,75 \text{ mm}$,

9. linear speed of belt transmission

$$V_1 = \omega_{\text{э.д.}} \cdot r_1 = 297 \cdot 160 = 47,52$$

here: $\omega_{\text{э.д.}}$ - the rotation speed of the electric engine $\omega_{\text{э.д.}} = 297 \text{ ref/s}$,

r_1 - the radius of the pulley

$$r_1 = 160 \text{ mm}$$

$$V_1 = V_2$$

10. Centrifugal impact of dust particles on the return disk.

$$F_n = \frac{m \cdot V_2}{R} = \frac{10 \cdot 10^{-6} \cdot 47,52}{0,315} = 0,002$$

here; m - the average weight of a dust particle $m = 10 \cdot 10^{-6} \text{ m}$,

R - the radius of the return washer, $R = 0,315 \text{ m}$,

Summary

The reason for the frequent clogging of these dust traps is the installation design of the return washer and the size of the suction section for the trapped dust is 50 mm. To eliminate this, the outer wall of the dust holder is specially hermetically sealed. At the beginning of the blockage, installation and its completion require a certain time, while the blade of the pneumatic transporter continues to work, the trapped dust is removed from the dust holder.

Used literature

1. Decision PQ-3408 of the President of the Republic of Uzbekistan dated November 28, 2017 "On measures to fundamentally improve the management system of the cotton industry".
2. N.A. Navruzov., I.D. Madumarov., N.M. Akhmatov., M.A. Akhmatov., Equipment for drying high-grade cotton raw materials. Textile problems #2/2009. 104-106 p.
3. Baltabayev S.D., Parpiyev A.P. Sushka khlopka-syrsa. Tashkent: Ukitchich, 1981.

Research Science and Innovation House