

**HEARING AIDS: WORKING PRINCIPLE AND FUNCTIONAL
MECHANISMS**

p.f.f.d, PhD, dotsent. Buzrukov To'lqin Omonovich

Email: tolqinbuzrukov5@gmail.com

Habibullayev Maxmud Bahrom o'gli

Termez University of Economics and Service

Faculty of Medicine

Abstract

Hearing aids are sophisticated electronic devices designed to improve hearing in individuals with hearing impairment. This article explores the working principles, structural components, and signal processing mechanisms of modern hearing aids. The study focuses on how sound waves are captured, amplified, processed, and delivered to the auditory system. Special attention is given to digital hearing aids, which utilize advanced algorithms for noise reduction and sound clarity. Understanding the functional mechanisms of hearing aids is essential for improving clinical outcomes and patient satisfaction. This paper follows the IMRAD structure to provide a comprehensive overview of hearing aid technology.

Keywords: hearing aid, auditory system, sound amplification, digital signal processing, hearing loss



PARTS OF A HEARING AID

1. Microphone
2. Flexible printed circuit board
3. Battery
4. Receiver
5. Antenna

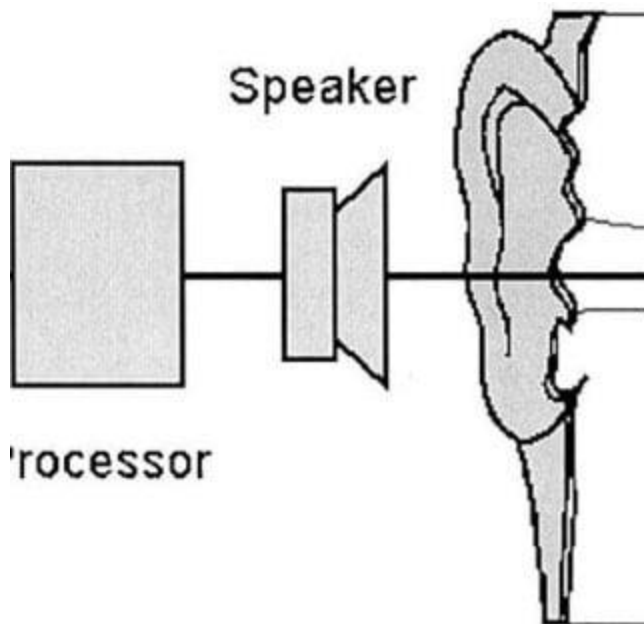
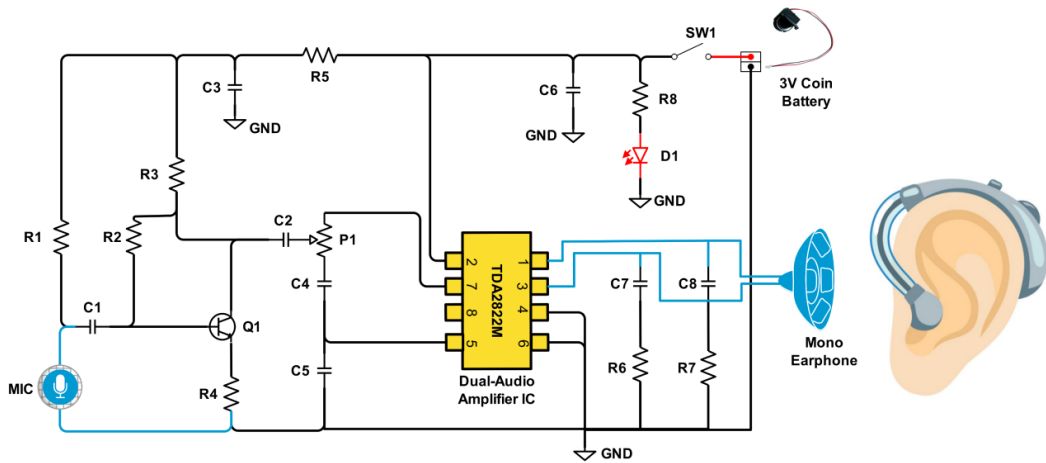
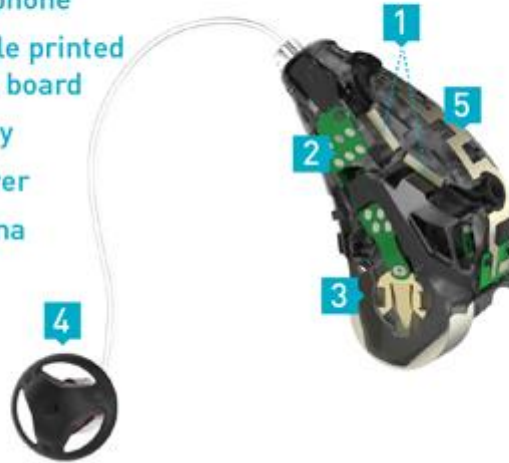

Introduction

Hearing loss is a global health concern affecting millions of people worldwide. According to the World Health Organization, over 1.5 billion individuals experience some degree of hearing impairment. Hearing aids serve as one of the most effective rehabilitative solutions for such patients.

The primary function of a hearing aid is to amplify sound signals and deliver them efficiently to the inner ear. Modern devices go beyond simple amplification and incorporate digital

signal processing, adaptive noise filtering, and frequency modulation. These innovations significantly enhance speech perception and environmental awareness.

This article aims to explain the working principles of hearing aids, focusing on their components, sound processing pathways, and technological advancements.

Materials and Methods

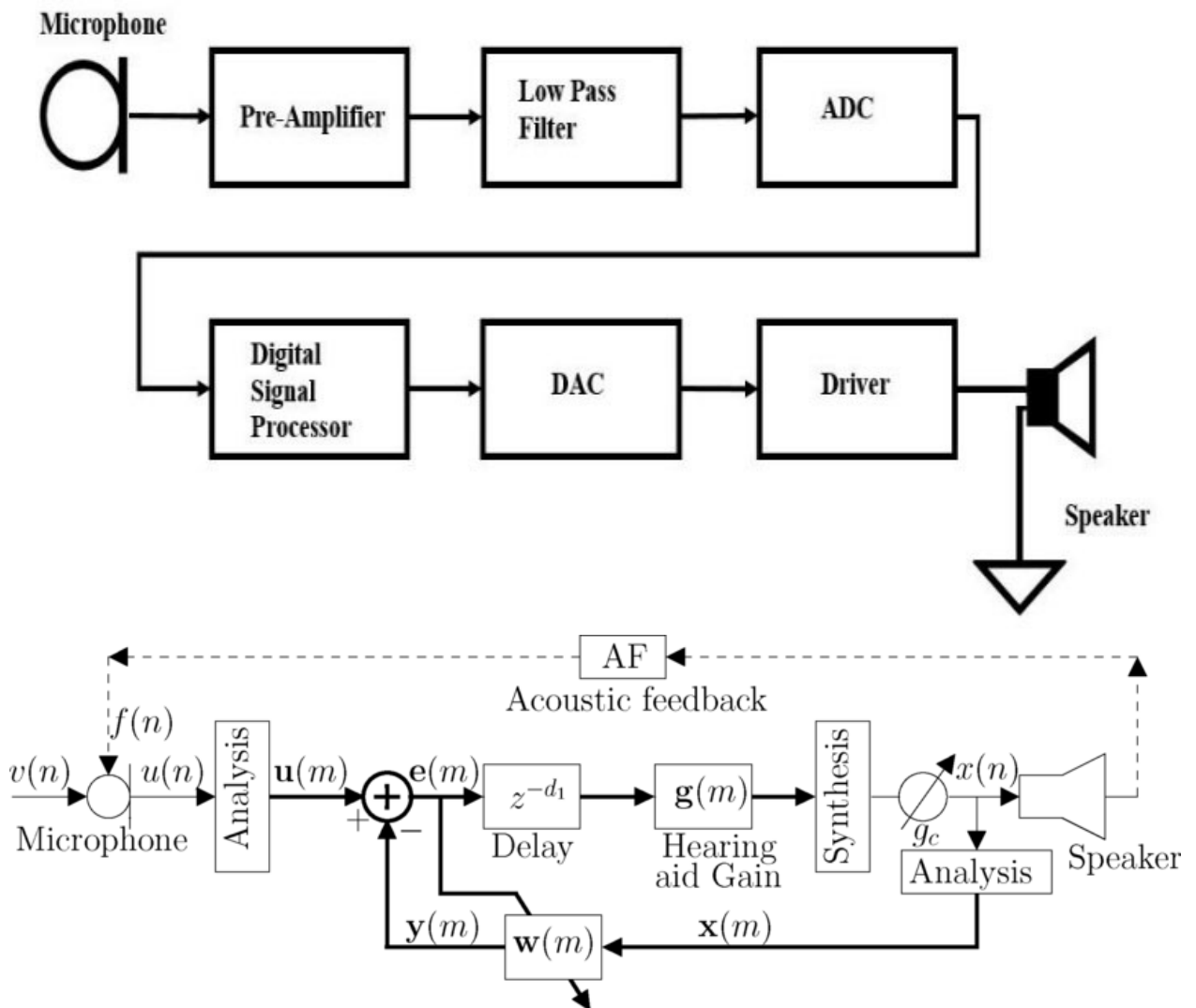

Hearing Aid

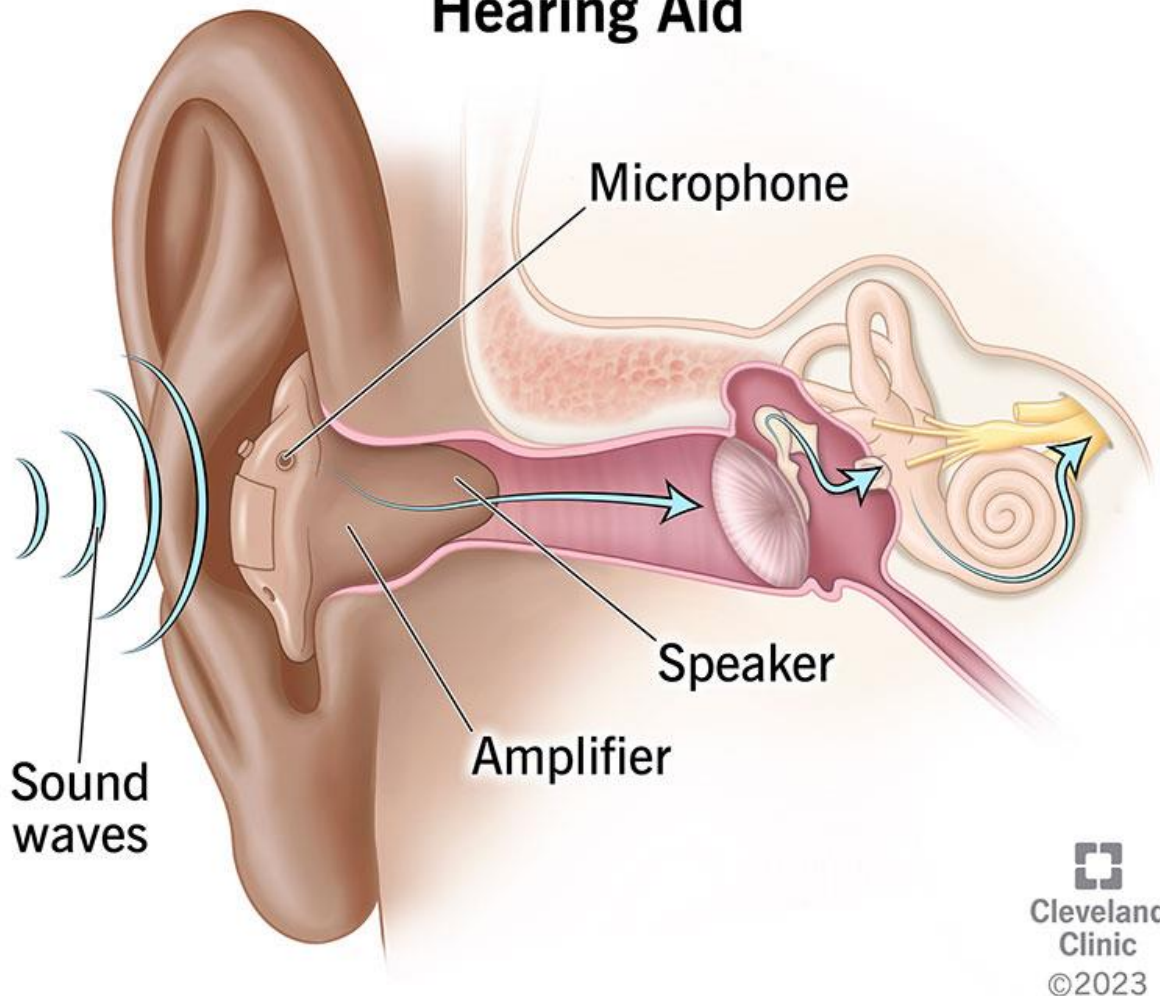

This study is based on a comprehensive review of scientific literature, textbooks, and clinical resources related to audiology and biomedical engineering. Sources include databases such as PubMed, Scopus, and Google Scholar.

The methodology involves:

- Analytical review of hearing aid components and their functions
- Comparative analysis between analog and digital hearing aids
- Evaluation of signal processing techniques used in modern devices
- Integration of diagrams and schematics to illustrate the working principles

No experimental procedures were conducted; this is a theoretical and descriptive research study.

Results

1. Main Components of Hearing Aids

A typical hearing aid consists of the following essential parts:

- **Microphone** – captures external sound waves
- **Amplifier (processor)** – increases signal strength and modifies sound
- **Receiver (speaker)** – converts electrical signals back into sound
- **Battery** – provides power
- **Control system** – adjusts volume and settings

2. Working Principle

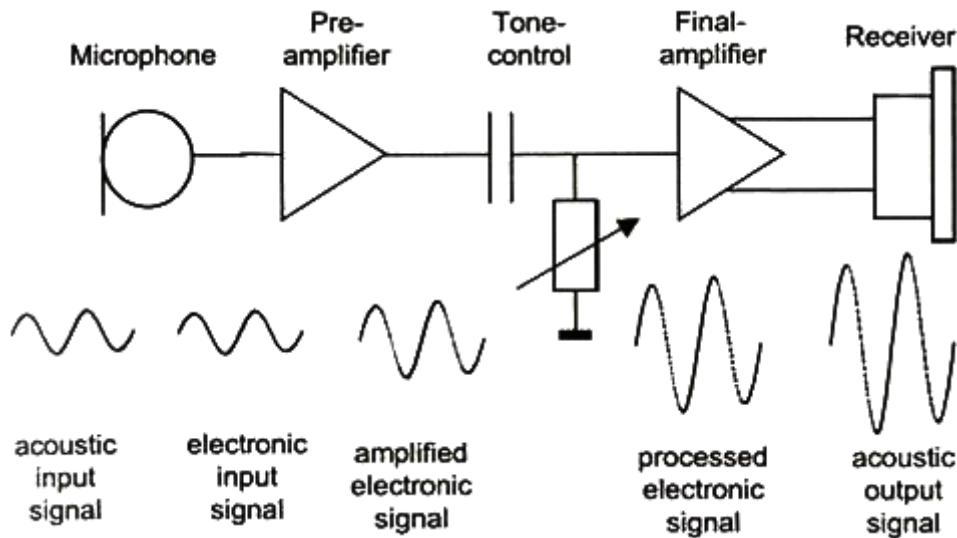
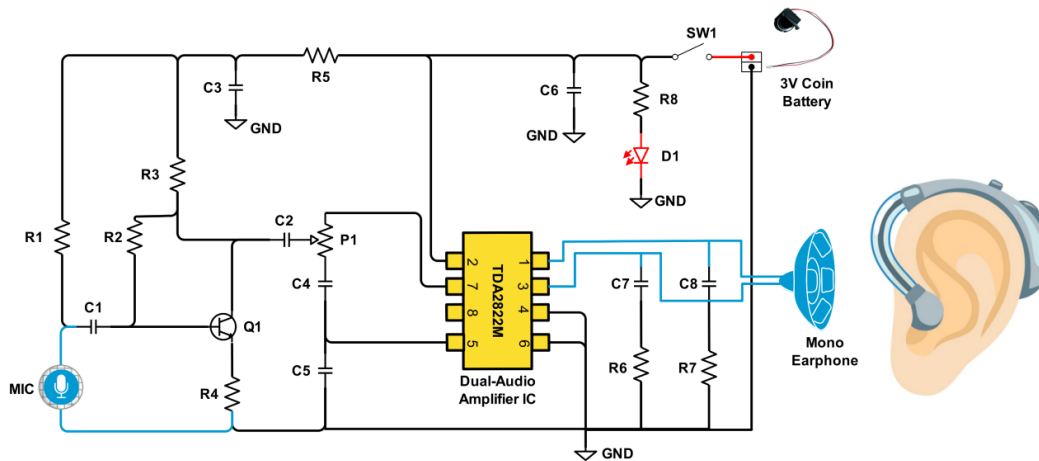

Hearing Aid

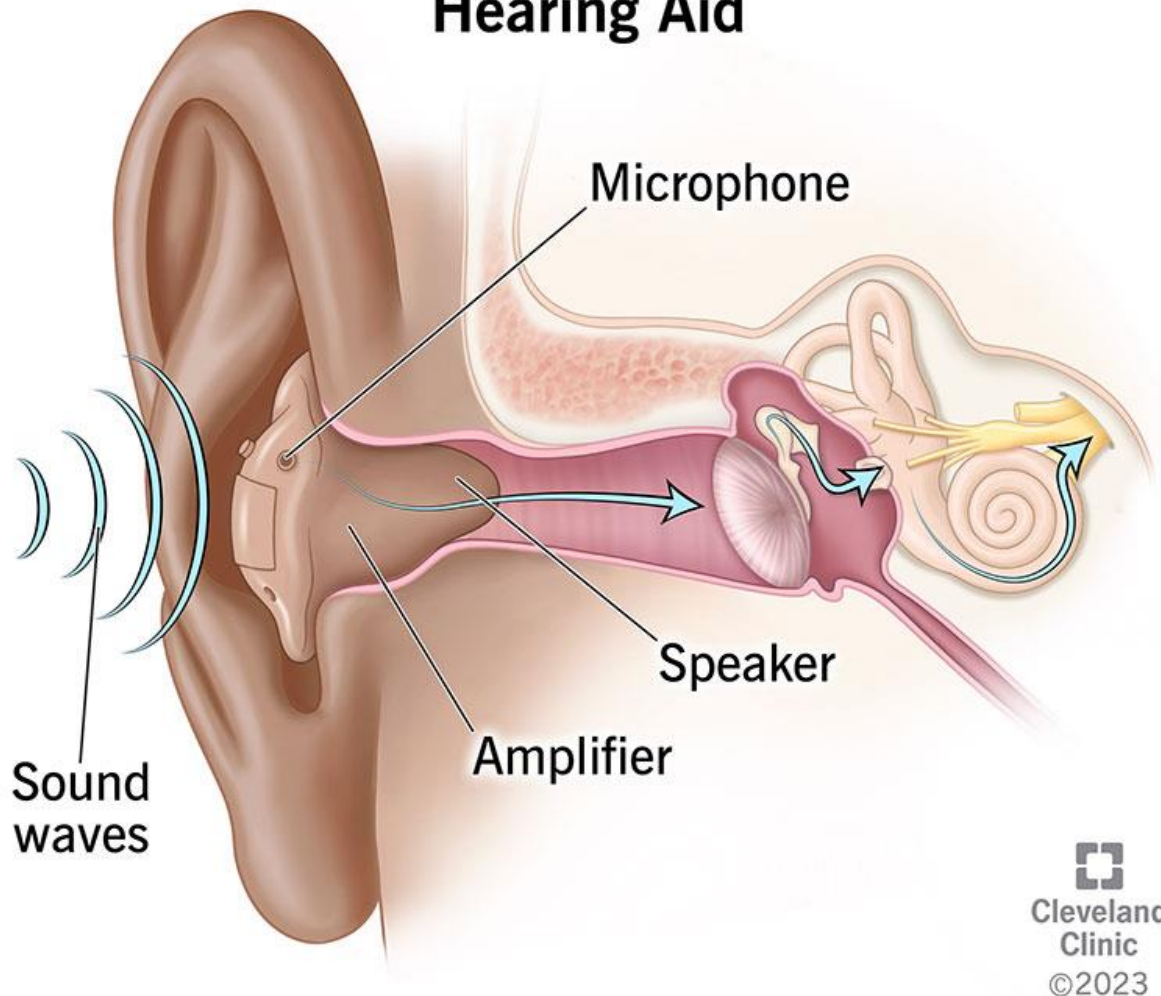

Cleveland
Clinic
©2023

The working mechanism of hearing aids can be summarized in sequential steps:

1. **Sound Collection** – The microphone detects sound waves from the environment
2. **Signal Conversion** – Acoustic signals are converted into electrical signals
3. **Amplification** – The amplifier increases signal intensity
4. **Signal Processing** – Digital processors filter noise and enhance speech frequencies
5. **Output Delivery** – The receiver sends amplified sound into the ear canal

3. Types of Hearing Aids

- **Analog Hearing Aids** – amplify all sounds equally
- **Digital Hearing Aids** – process signals using algorithms
- **Behind-the-ear (BTE)** and **In-the-ear (ITE)** models

Discussion

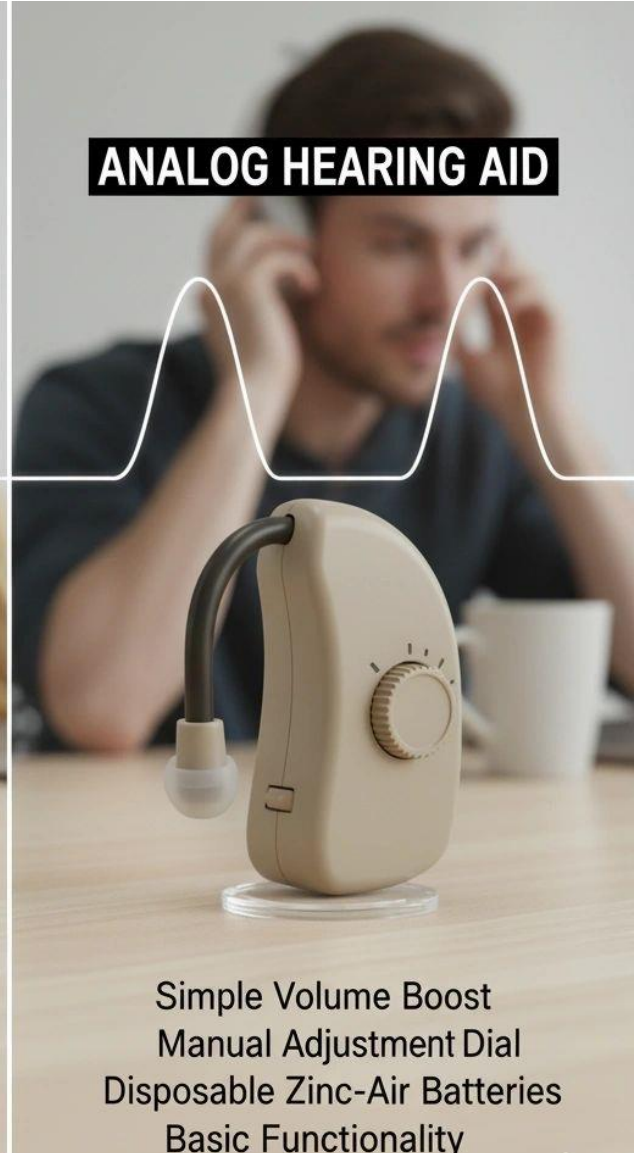

Enhanced Neural Tracking of Relevant Speech with Noise Reduction Activated

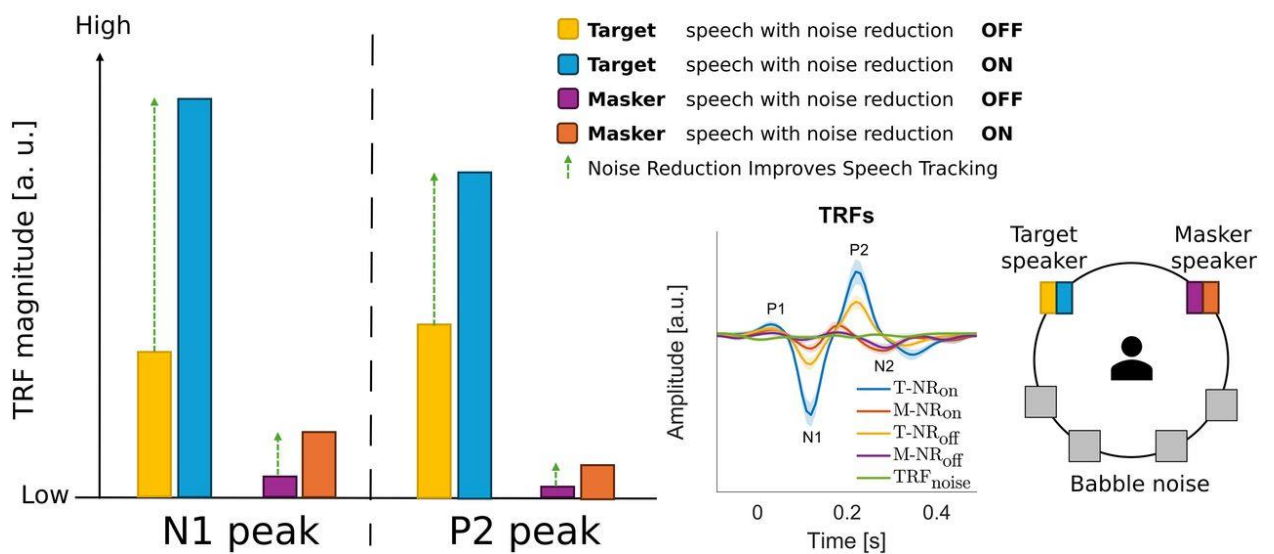

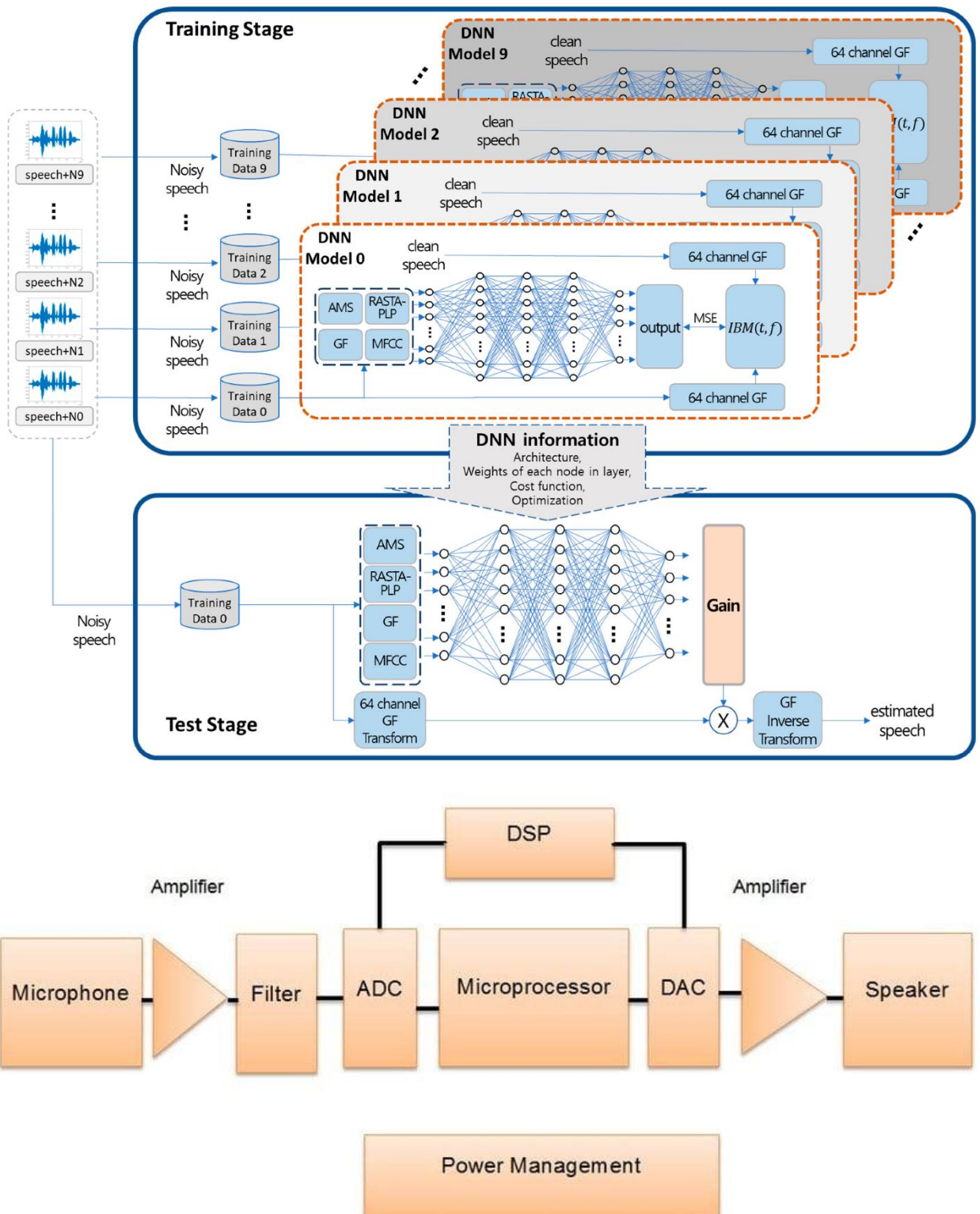

Modern hearing aids represent a significant advancement over earlier analog devices. Digital hearing aids, in particular, provide customized amplification tailored to individual hearing loss profiles. They can selectively amplify frequencies, reduce background noise, and enhance speech clarity.

Advanced features include:

- Noise reduction algorithms
- Directional microphones
- Feedback cancellation
- Wireless connectivity (e.g., Bluetooth integration)

Despite these advancements, challenges remain such as cost, maintenance, and user adaptation. Future developments aim to integrate artificial intelligence for real-time sound optimization.

Conclusion

Hearing aids are essential biomedical devices that significantly improve the quality of life for individuals with hearing impairment. Their working principle involves capturing sound, converting it into electrical signals, amplifying and processing it, and delivering it back as audible sound.

Technological advancements, especially in digital signal processing, have transformed hearing aids into highly efficient and customizable devices. Continued research and innovation are expected to further enhance their functionality and accessibility.

References

1. Dillon, H. (2012). *Hearing Aids*. Thieme Medical Publishers. (Indexed in Scopus)
2. World Health Organization (2021). *World Report on Hearing*.
3. Katz, J. (2015). *Handbook of Clinical Audiology*. Wolters Kluwer.
4. Bentler, R. (2005). Effectiveness of directional microphones. *Journal of the American Academy of Audiology*. (Indexed in PubMed)
5. Stone, M. A., & Moore, B. C. (2008). Quantifying the effects of fast-acting compression. *Journal of the Acoustical Society of America*.